

Steinway & Sons Model LS
**INSTALLATION
MANUAL**

TABLE OF CONTENTS

TABLE OF CONTENTS.....	2
INTRODUCTION.....	3
COMPLIANCE	3
MODEL LS MUSIC SYSTEM PRE-INSTALLATION	4
INSTALLATION.....	6
TRADEMARKS.....	17
SERVICE INFORMATION	18

INTRODUCTION

Please read all material carefully prior to installation. If you need additional assistance, contact your Steinway Lyngdorf representative or email service@steinwaylyngdorf.com.

COMPLIANCE

WEEE

The European Parliament and the Council of the European Union have issued the Waste Electrical and Electronic Equipment Directive. The purpose of the Directive is to prevent waste of electrical and electronic equipment and to promote reuse, recycling, and other forms of waste recovery. Steinway Lyngdorf products and the accessories packed with them are subject to the WEEE Directive. Please dispose of any waste materials in accordance with your local recycling regulations. Products and equipment which must be collected for reuse, recycling, and other forms of recovery are marked with the icon of the crossed-out waste receptacle.



FCC

Steinway Lyngdorf products and accessories comply with parts 15 and 68 of the FCC rules. Operation is subject to the following two conditions: (1) this device may not cause harmful interference; and (2) this device must accept any interference received, including any interference that may cause undesired operation. Changes or modifications not expressly approved by the party responsible for compliance could void the user's authority to operate the equipment. Equipment marketed to a consumer must be capable of complying with the necessary regulations in the configuration in which the equipment is marketed.



MODEL LS MUSIC SYSTEM PRE-INSTALLATION

Unpacking the Model LS

Carefully remove the loudspeaker units and accessories from the carton and check for shipping damage. Contact both the shipper and your Steinway Lyngdorf representative immediately if the unit bears any sign of damage from mishandling. Note: Keep shipping carton and packing material for future use or in the unlikely event that the unit needs servicing. If this unit is shipped without the original packing, damage could occur and void the warranty.

Inventory

Check to ensure that all necessary product components have been delivered. Report all discrepancies to your Steinway Lyngdorf representative immediately.

- Model LS left, right, center, surround, and boundary woofer loudspeaker units (depending on setup). Brackets for securing the individual loudspeaker units to each other are attached to the units prior to shipping.

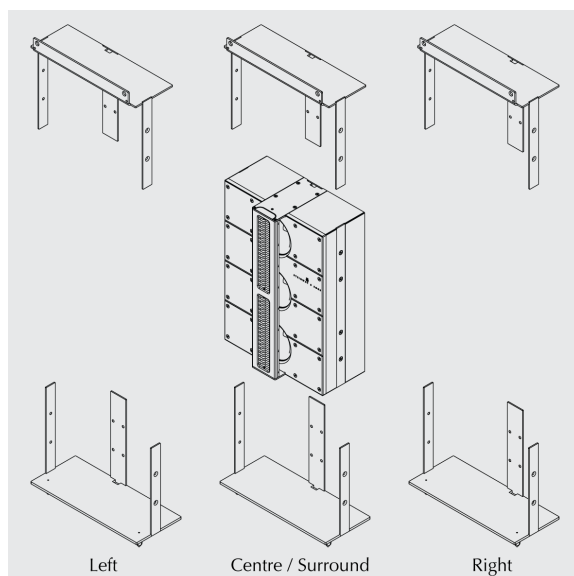

- Brackets for securing the top and bottom speaker unit in each stack.

Note that the Model LS boundary woofer does not include these brackets. Instead, rubber feet and metal spikes are included for mounting on the bottom boundary woofer in each stack. Your choice of feet or spikes depends on the floor surface on which the boundary woofers will stand. Use spikes for carpeted floors, and the rubber feet for hardwood or tiled floors.

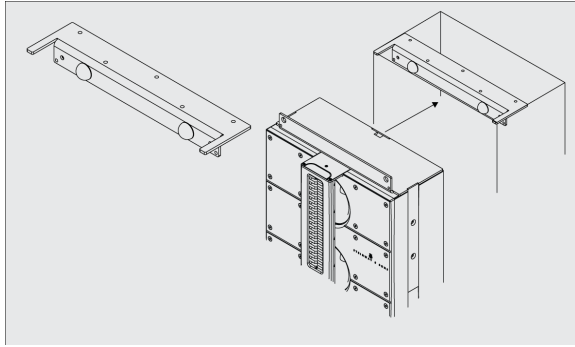

- In-wall-mounted brackets for securing the top of each stack to the wall. No in-wall-mounted brackets are necessary with Model LS boundary woofers, nor are such brackets included with the boundary woofers.

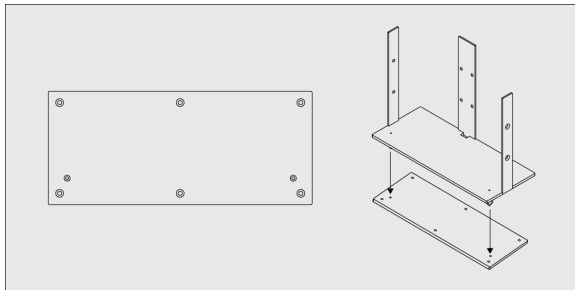

- Spike sheets for Model LS left, right, center, and surround loudspeaker stacks, one spike sheet per stack. These sheets protect the floor against damage from the spikes mounted on the bottom of each loudspeaker stack.

Additional items in inventory include:

- SpeaKon connectors (NL 4 FC)

INSTALLATION

Prepare the Wall for the Speaker Stacks

For proper mounting of a Model LS loudspeaker stack, a rectangular cutout with the following dimensions must be made in the wall:

Model LS Left, Center, Right and Surround

- Height
 - For a stack of 4 units: at least 206.3 cm (81.22 in) and no more than 207.5 cm (81.69 in) in height.
 - For a stack of 5 units: at least 255.3 cm (100.62 in) and no more than 256.5 cm (101.78 in) in height.
 - For a stack of 6 units: at least 304.4 cm (119.8 in) and no more than 305.4 cm (120.2 in) in height.
 - For each additional unit: add 49.2 cm (19.4 in) to the height of the wall cutout. The spikes mounted on the bottom loudspeaker unit can be adjusted so that the stack fits the wall cutout precisely.
- Width at least 35.5 cm (13.98 in) and no more than 36.0 cm (14.17 in)
- Depth at least 15.5 cm (6.1 in)

Model LS Boundary Woofer

- Height (number of speakers in stack) x 73.8 cm (29.1 in) + (height of feet or spikes)
- Width at least 35.5 cm (13.98 in) and no more than 36.0 cm (14.17 in)
- Depth at least 33.5 cm (13.2 in)

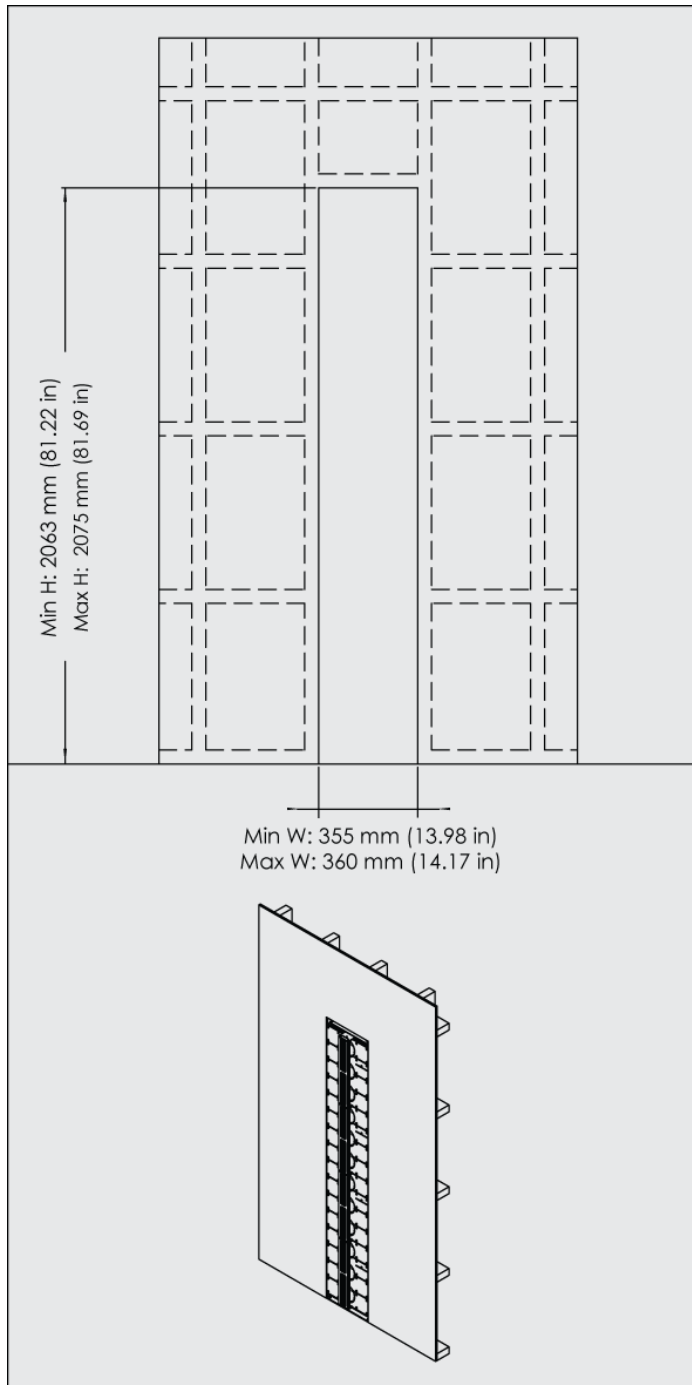

The Speakon loudspeaker cables for connection of stacks to the appropriate Model A1 amplifiers should exit the wall behind each stack at the following positions:

- Model LS Left: 29.0 cm (11.4 in) above floor, along the vertical axis.
- Model LS Right: 29.0 cm (11.4 in) above floor, along the vertical axis.
- Model LS Center: 29.0 cm (11.4 in) above floor, 3.0 cm (1.2 in) to the left of the vertical axis.
- Model LS Surround: 45.5 cm (18.0 in) above floor, 5.0 cm (2.0 in) to the left of the vertical axis.
- Model LS Boundary Woofer: 13.0 cm (5.1 in) above floor, 8.0 cm (3.1 in) to the left of the vertical axis.

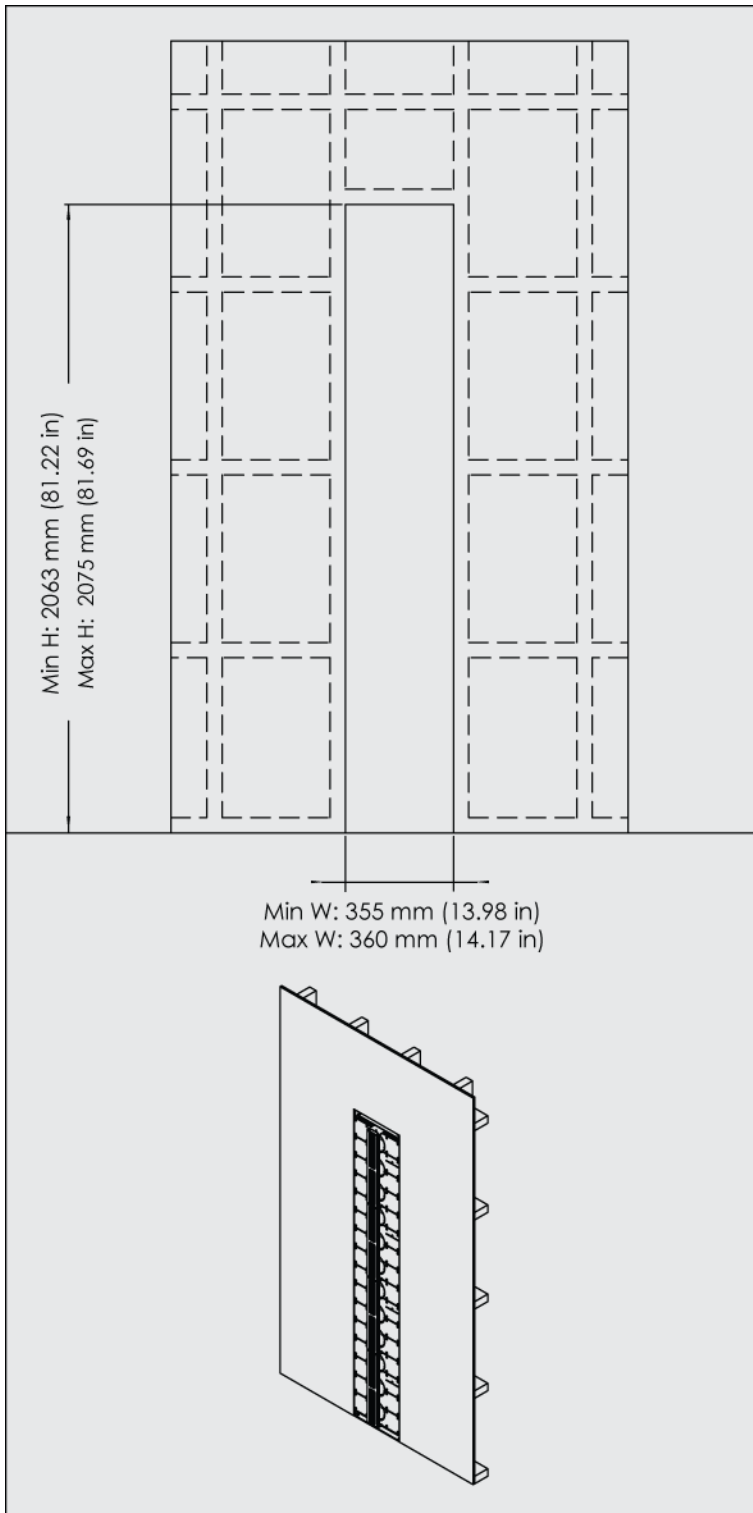

Example: Proper socket placement for mounting of a Model LS Center loudspeaker stack.

Arrange the individual speaker units in a stack. For each loudspeaker stack, place the loudspeakers with the front side down on the floor, preferably close to the wall cutout in which the stack is to be mounted. Make sure that the floor is covered with fabric – such as carpeting - to avoid scratching the loudspeakers.

⚠ NOTE! Before placing the LS Center loudspeakers front side down, lay down two rows of extra

material, such as Styrofoam, which can support the loudspeakers on each side of the tweeter units. The tweeter units are fragile and cannot support the weight of the stack without being damaged. Ensure that the two rows of Styrofoam extend beyond the bottom edge of the stack in such a way that they, and not the tweeter units, support the weight of the stack when the stack is raised upright and mounted in the wall cutout.

Place the loudspeakers in order, with the bottom loudspeaker in the stack closest to the bottom edge of the wall cutout in which the stack is to be mounted. This facilitates easy mounting when connections are complete, as the stack can be tilted directly into place.

Remove the Brackets from Each Speaker Unit

All Model LS loudspeaker units, including boundary woofers, are equipped with metal brackets from the factory. When these brackets are mounted correctly on the left, right, and rear sides of the units, they align and secure the individual units in a stack to each other. Using a TORX 30 type screwdriver, remove the screws securing the brackets to the loudspeakers, keeping the brackets and screws close at hand.

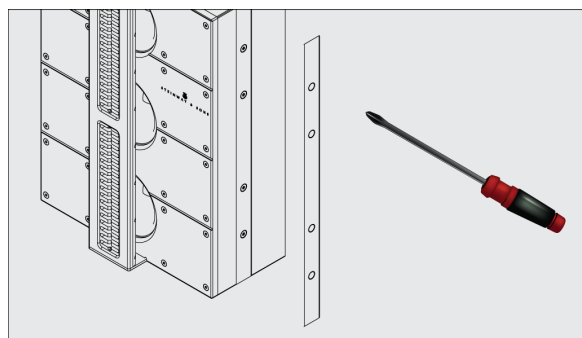

Mount the Side Brackets on Each Stack

Model LS boundary woofers, right, left, center, and surround loudspeakers: Using the screws you have just removed from the side and rear brackets, secure the side brackets to the stack as shown below. The bracket must bridge two loudspeakers in such a way that the bracket can be affixed to each loudspeaker with two screws.

First, insert the screws into all four holes and tighten them by hand until the head of each screw protrudes 1-2 mm, then tighten the screws with a TORX 30 screwdriver. If you mount the bracket one screw at a time, there is a risk that the last screw will not be fully aligned with the hole. Tightening the last screw can then result in the screw thread being stripped, rendering the screw useless and resulting in an unstable loudspeaker stack.

When the side brackets are mounted on the stack correctly, there are two side brackets left over. These are to be mounted on the rear of the stack, but only after the loudspeaker cables have been run as described below.

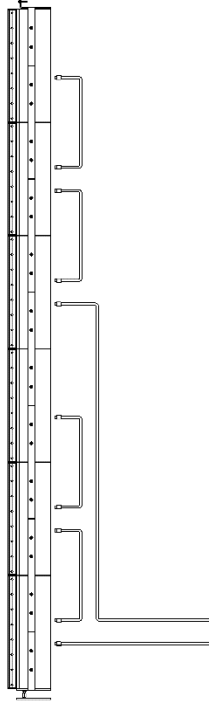
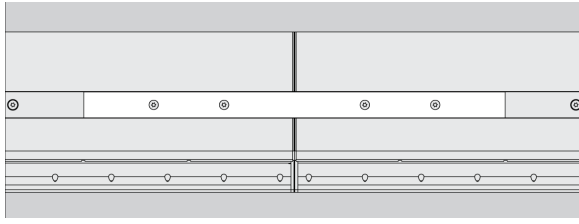

Daisy chain connection for Model LS right, left, center and surround loudspeakers in a stack of 6.

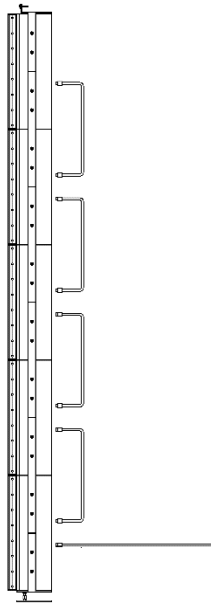

Daisy chain connection for Model LS right, left, center and surround loudspeakers in a stack of 4.

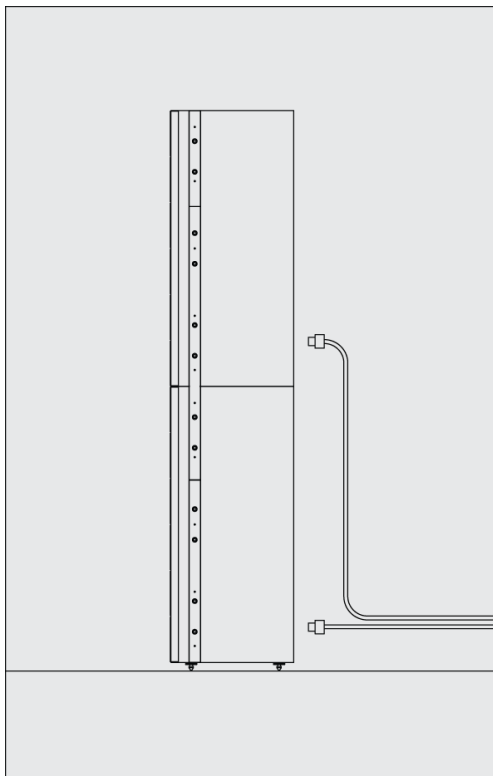

1:1 connection of Model LS boundary woofers

Connect the Loudspeaker Cables

Model LS right, left, center, and surround loudspeakers: The socket pairs on the rear of the Model LS loudspeakers and the Speakon cables included with the loudspeakers facilitate connection of the individual units in a stack in a daisy chain. As shown to the left, the cable connecting each stack to a Model A1 amplifier is connected to the bottom socket on the bottom loudspeaker unit in each stack. A cable then connects the top socket on the bottom loudspeaker to the bottom socket on the loudspeaker unit above it, and so on to the top of the stack.

Model LS boundary woofers: Unlike the other Model LS loudspeakers, the boundary woofers must be connected individually to their respective Model A1 amplifiers, and cannot be connected in a daisy chain.

Mount the Brackets for the Top and Bottom Loudspeakers in a Stack

Model LS right, left, center, and surround loudspeakers: Using the same TORX 30 screwdriver and the screws you have just removed from the side and rear brackets, secure the dedicated top and bottom brackets to the loudspeakers in their respective stacks as shown to the right. The top and bottom brackets for the Model LS center loudspeaker are identical to the top and bottom brackets for the Model LS surround loudspeakers.

Model LS boundary woofers: There are no top or bottom brackets for the LS boundary woofers. For the bottom unit in a stack, attach spikes or rubber feet, depending on the floor surface. For middle and top units in a stack, attach rubber feet to each unit to stabilize the stack, as the rubber feet fit precisely into corresponding recessions in the boundary woofers beneath.

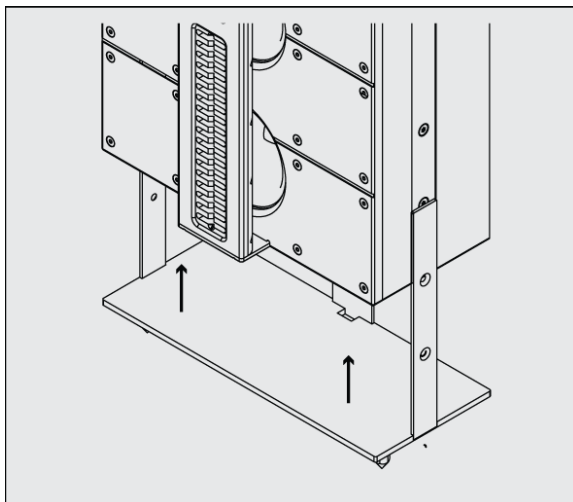
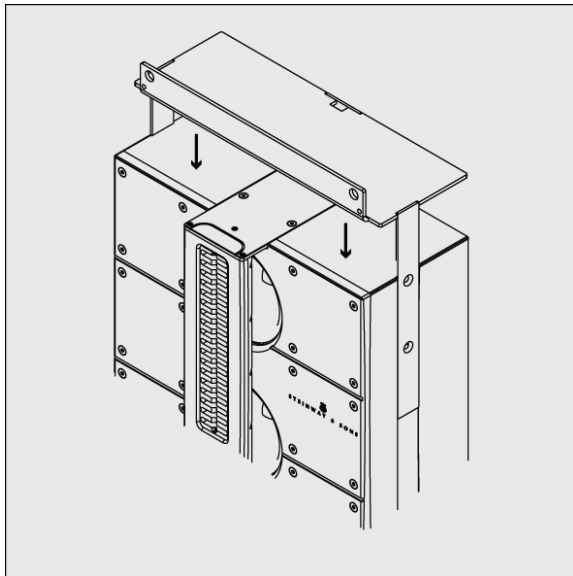

Mount the Remaining Side Brackets

Model LS boundary woofers, right, left, center, and surround loudspeakers: When cable connections are complete, use a TORX 30 screwdriver to mount the remaining side brackets on the rear of the loudspeaker stacks, bridging the individual loudspeakers as shown previously. The brackets on the rear of the loudspeaker stacks will partially cover the socket panels, so make sure connections are complete before mounting the remaining brackets on the rear of the stack.

Mount the Wall Bracket in the Wall

Model LS right, left, center, and surround loudspeakers: Mount the wall bracket on the bottom side of the horizontal stud at the top of the wall cutout as shown, fixing the bracket to the stud with five screws. Note that the purpose of the wall bracket is to stabilize the stack and not to bear its weight; the stack stands on four spikes attached to the bottom bracket, and these spikes are placed in their respective holes in the spike sheet, which protects the floor.

 **NOTE!** Never use countersunk screws when mounting the loudspeaker units.

There are no top brackets for the LS boundary woofers.

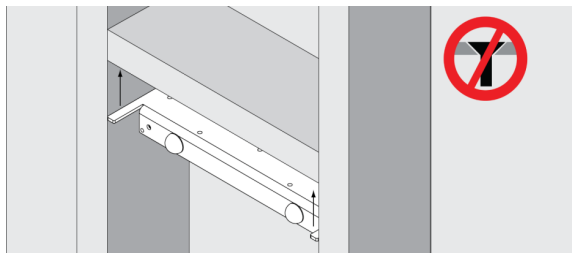

Mount the Speaker Stack in the Wall

When all connections are complete and the relevant brackets mounted on the loudspeakers and in the wall cutout, the stack can then be mounted in the wall cutout. Before mounting a loudspeaker or boundary woofer stack on a non-carpeted surface, such as a wooden floor, first place the spike sheet on the floor in the wall cutout so that the front edge of the spike sheet is aligned with the outer surface of the wall. This ensures that the front of the stack protrudes from the wall the proper amount for optimal sound performance. Tilt the stack until it stands in an upright position in the wall cutout, ensuring that the spikes attached to the bottom bracket are aligned with their respective holes in the spike sheet.

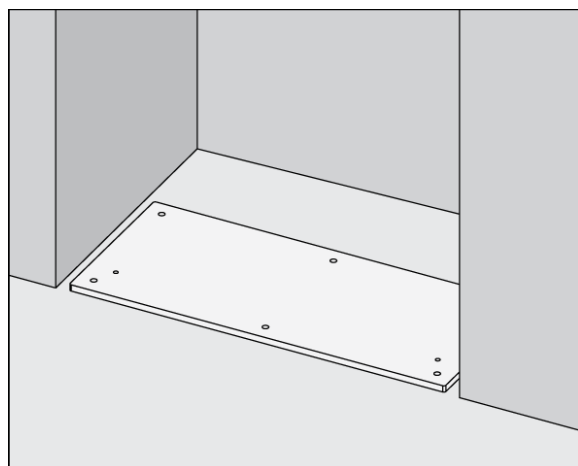

⚠ NOTE! For your own safety, do not attempt to raise the stack by yourself. As a rule of thumb, there should be one person involved in lifting a loudspeaker stack for every two loudspeaker units in the stack; so a stack of six loudspeaker units requires at least three people to lift. For stacks of boundary woofers, there should be one person involved in lifting for every individual unit in the stack, so a stack of two boundary woofers requires at least two people to lift.

Check that the screw holes in the stack's top bracket are aligned with their corresponding holes in the wall bracket. If not, lower the stack to the floor once more and adjust the height of the spikes. This is done by rotating the spikes: clockwise to decrease the height of the stack, and counter-clockwise to increase it. Similarly, you can adjust the height of a Model LS boundary woofer stack by adjusting the height of the rubber feet or spikes on the bottom unit in the stack. When the holes in the loudspeaker stack's top bracket are aligned with the holes in the wall bracket, you can then secure the stack to the wall bracket with the screws included with the system. The screws must be tightened completely.

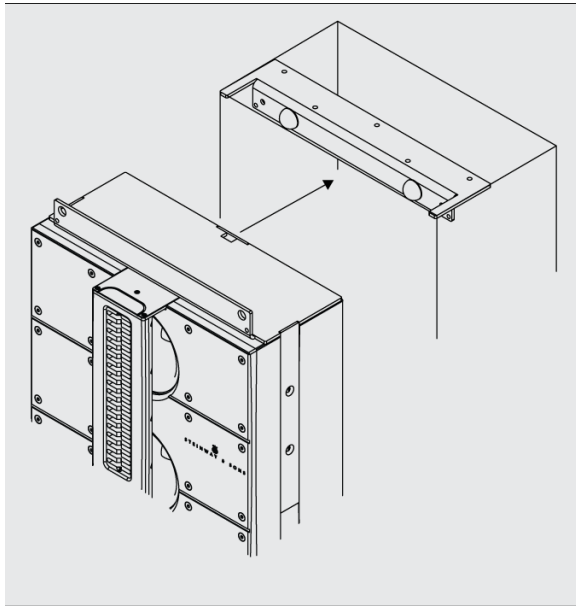

Please note that there will be a space of roughly 1-2 millimeters between the heads of these screws and the front side of the stack's top bracket, even after the screws have been tightened completely. This ensures that the vibration of the loudspeaker during use is not transplanted to the wall construction, while at the same time ensuring that the stack cannot tip over.

TRADEMARKS

DTS is a registered trademark & the DTS logos and Symbol are trademarks of DTS, Inc. Manufactured under license under U.S. Patent #'s: 5,451,942; 5,956,674; 5,974,380; 5,978,762; 6,226,616; 6,487,535 & other U.S. and worldwide patents issued & pending. DTS is a registered trademark and the DTS logos, Symbol, DTS-HD Master Audio are trademarks of DTS, Inc. © 1996-2008 DTS, Inc. All Rights Reserved.

HDMI, the HDMI Logo and High-Definition Multimedia Interface are trademarks or registered trademarks of HDMI Licensing LLC.

Dolby and the double-D symbol are registered trademarks of Dolby Laboratories.

This product incorporates technology that is protected by U.S. patents and other intellectual property rights. Use of this technology must be authorized by Macrovision, and is intended for home and other limited viewing uses only, unless otherwise authorized by Macrovision. Reverse engineering or disassembly is prohibited.

This item incorporates copy protection technology that is protected by U.S. patents and other intellectual property rights of Rovi Corporation. Reverse engineering and disassembly are prohibited.

SERVICE INFORMATION

In order to obtain warranty service you must contact your original dealer or the Steinway Lyngdorf distributor of the region or country where you are located. If you have trouble locating an authorized representative, please contact the Steinway Lyngdorf Customer Service Department using the contact information at www.steinwaylyngdorf.com, or you may email service@steinwaylyngdorf.com.

Steinway Lyngdorf

Ulvevej 28

DK 7800 Skive

Denmark

In some cases, the Customer Service Department may solve a service problem without the need of repair or any other measures, thereby avoiding further inconvenience or delay. In some cases it may be necessary to return the equipment to Steinway Lyngdorf or an authorized service provider for repair; therefore, it is recommended that you save your original packing materials. Steinway Lyngdorf will not be responsible for any damage due to unauthorized packing or shipment in non-original packing materials. If return is made in authorized packaging, risks are borne by Steinway Lyngdorf. Additional charges may occur if new packing materials are required for return shipment.

STEINWAY LYNGDORF